

## SA SELECTORIZED SERIES

## SA034 - LATERAL RAISE



## PRODUCT OVERVIEW

The SA034 is a selectorized strength machine purpose-built for targeted training of the middle deltoid, ideal for commercial gyms and personal training studios. Compared to traditional dumbbell lateral raises, the SA034 features a rotating arm pad system that significantly reduces forearm involvement, improving middle deltoid isolation and muscle recruitment efficiency.

The rotating arm pads follow the natural path of the shoulder joint, minimizing friction between the arm and pad and allowing for precise stimulation of both the middle and rear deltoid heads.

An integrated support handle provides added grip stability throughout the movement, enhancing comfort and control. The 6-position adjustable seat adapts to users of various heights and body types, helping establish an optimal pressing posture and improving alignment.

With a compact, durable frame and biomechanically sound movement path, the SA034 delivers consistent performance, making it an essential solution for focused shoulder development.

# SPECIFICATIONS & KEY FEATURES

## Specifications

Dimension:	1179*1159*1566mm
Total Weight:	233kg
Weight Stack:	100kg
Max Weight Stack:	125kg

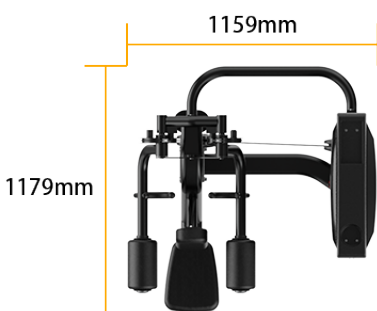
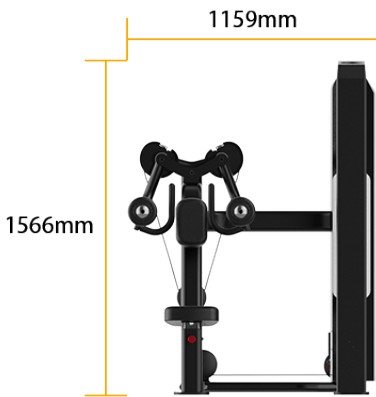
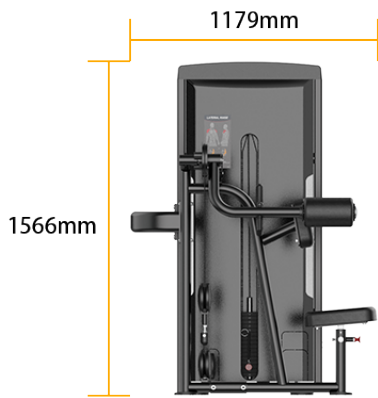

## Product Features



### Rotating Arm Pad System

Minimizes forearm activation and friction, enhances middle deltoid isolation, and supports a smooth, shoulder-friendly motion path.

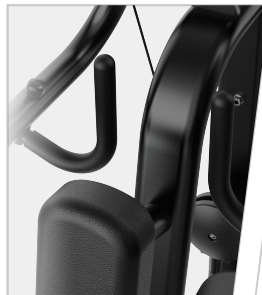

### Integrated Support Handle

Provides grip assistance and improved control throughout lateral raise movements, increasing overall movement stability.



### 6-Position Adjustable Seat

Accommodates users of different heights and physiques, helping optimize force alignment and training posture.

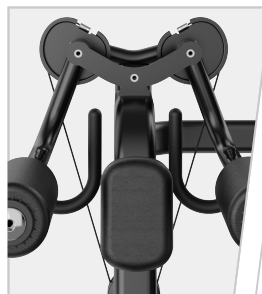

### Biomechanically Natural Movement Path

Follows the shoulder's anatomical trajectory, reducing compensation and improving the precision of muscle activation.